

## MDV-400 Motorized Drain Valves

### A versatile valve that will never clog.

For the most dependable drain, install the MDV-400. The MDV-400 consists of a heavy duty electric actuator, an integral adjustable timer, and a full ported ball valve. The MDV-400 manages virtually any fluid in a variety of applications, including compressed air condensate, cooling tower filters, and separators. The MDV-400 is available in two models.

**MDV-400I** - For dependable draining at consistent intervals choose the "I" version. A power on LED and test button are located on the exterior of the top cover. The adjustable valve cycle controls are protected within the enclosure. The MDV-400I is suitable for indoor or outdoor service.

**MDV-400L** - For real time operating status and quick adjustments to the valve cycle time choose the "L" version. An external LCD display and keypad makes changing the valve actuation intervals easy. You'll never wonder when the valve is going to actuate, with a clear countdown display. The MDV-400L is suitable for indoor service only.

For on demand actuation wire the MDV-400 to a level switch or differential pressure switch.

### MDV-400 drain valves are ideal for:

- Moisture Separator
- Sediment filter back washing
- Compressor intercoolers
- Receiver tanks
- Drop legs
- Coalescing filters
- Compressed air dryers

### FEATURES

Adjustable timer

Powerful motor

Full ported ball valve

Control by either timer or external switch



### BENEFITS OF THE MDV SERIES

Never clogs // Reliable // Easy to install

[vanairsystems.com](http://vanairsystems.com)

## SPECIFICATIONS

- Supply power: 115-1-50/60; 230-1-50/60
- Valve size: 1/2", 3/4", 1" NPT
- Valve body: brass or stainless steel
- Maximum working pressure: 600 PSIG (brass); 900 PSIG (stainless)
- Temperature range:  
MDV-400I: 0 to 120°F  
MDV400-L: 40 to 120°F
- Valve size: 1/2", 3/4", 1" NPT
- 8 foot cord

## MDV-400I

- Power on LED
- External test button
- Internal timing adjustment
- Demand draining capability
- Cycle time: 30 minutes to 30 hours
- Open time: 5, 10, 15, and 20 seconds

## MDV-400L

- LCD cycles status display
- Demand draining capability
- External test function
- External keypad timing adjustment
- Cycle time: 1 minute to 99 hours, 59 minutes
- Open time: 1 second to 99 minutes, 59 seconds

## OPTIONAL EQUIPMENT

- 12 VDC, 24 VDC
- 1 1/2" to 3" valve (brass)
- 1 1/2", 2" valve (stainless)
- Alarm contact wiring kit
- Level switch kit
- Alarm contacts

## DIMENSIONS & SPECIFICATIONS

Valve Connection Size	A		B		C		Weight	
	in	cm	in	cm	in	cm	lbs	kg
1/2 NPT	7.02	17.8	5.58	14.2	4.74	12.0	8.2	3.7
3/4 NPT	7.51	19.1	5.75	14.6	4.74	12.0	8.4	3.7
1 NPT	7.83	20.0	6.06	15.4	4.74	12.0	8.8	4.0

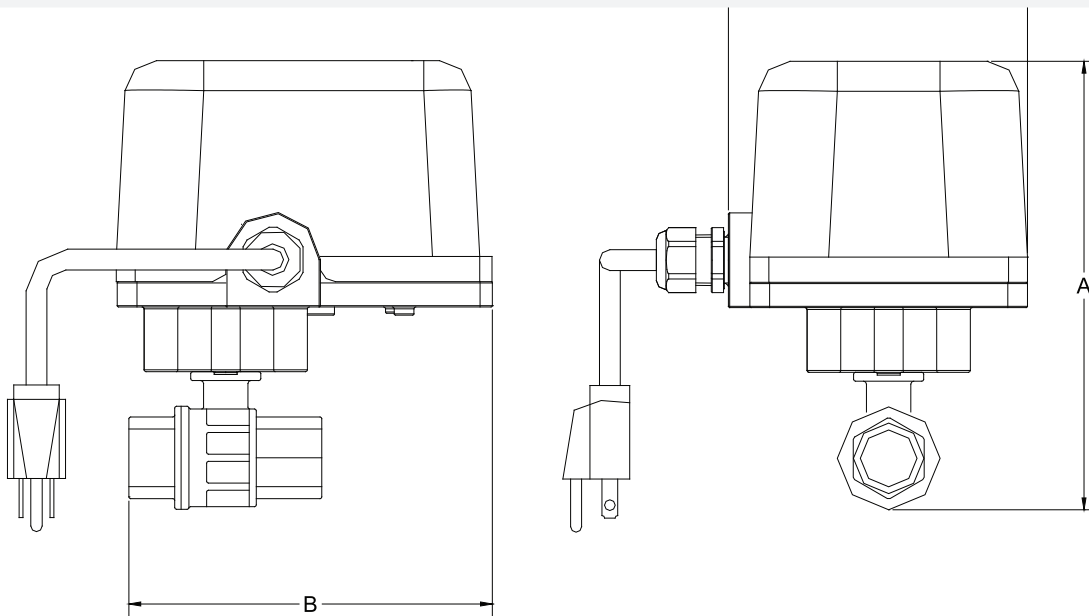

2950 Mechanic Street, Lake City, PA 16423, USA | Toll Free Phone 800-840-9906 | Corporate Fax 814-774-0778 | Order Entry Fax 814-774-3482

Distributed By:

**Air & Vacuum Process, Inc.**

Phone: 281-866-9700

Fax: 281-866-9717

Email: [sales@airvacuumprocess.com](mailto:sales@airvacuumprocess.com)



---

## MDV Series - PDF Downloads

---

### Installation, Operation and Maintenance Manuals

---

MDV-400I



MDV-400L



MDV-400 Parts List



MDV 400 Level Switch & Alarm



### Sales Drawings

---

MDV-400

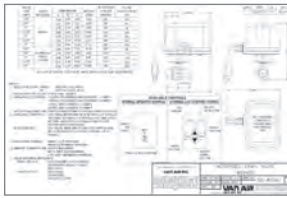

### Instructional Video

---

MDV-400 Automatic Drain Valve

