



DS Series Features

- Removable pre-sedimentation tank.
- Tapered carbon bag chambers.
- Pre-adsorber protects carbon adsorbers.
- Multiple condensate connection ports.
- Unique knob-adjustable oil drain tray.
- Water purity sample port and test kit.
- Easy to install, operate and maintain.

DS Series Sizing

Consider these factors when sizing an oil/water separator:

- The capacity of the compressed air system.
- The type of compressor in use.
- The type of lubricant used by the compressor.
- Whether or not a refrigerated air dryer is in use.
- Ambient temperature.
- Relative humidity.

The Aircel DS Oil/Water Separators utilize gravity to separate oil/water mixtures and purify the condensate to a residual oil content of 20 ppm or lower. Designed to meet or exceed those discharge levels as efficiently and economically as possible. The DS Oil/Water Separator is available in seven models ranging from 70 to 4,500 scfm.

The need for condensate management occurs when liquid condensate is generating at several points throughout a compressed air system, including the outlet of the compressors itself, within accumulator tanks, cyclone separators, coalescing filters and refrigerated air dryers. Whenever condensate forms, it must be removed from the compressed air system and discharged in a manner that is both environmentally sound and economical.

The amount of condensate generated within a compressed air system can be surprising. As an example, a 500 scfm system operating in ambient conditions of 60°F and 65% relative humidity can generate nearly 2 gallons of liquid condensate per hour. That condensate, however, will be generated at a number of points within the system. All of this condensate must be removed from the compressed air system. This is accomplished with the use of drain valves.

DS SERIES How it Works

- 1 Liquid condensate and compressed air enter the pressure relief chamber at the top of the unit.
- 2 A foam coalescing pad captures condensate droplets that are entrained in the expanding and exhausted air stream, which exits the top of the unit.
- 3 Liquid condensate enters a removable pre-sedimentation chamber where solid particles are separated and captured.
- 4 Condensate exits the pre-sedimentation chamber by passing through a coalescing foam block which begins the process of oil-water separation.
- 5 Condensate flows into and fills the primary settling chamber where gravity separation of liquid oil and water takes place.
- 6 Separated oil is skimmed from the surface of the settling chamber through an adjustable oil drain tray.
- 7 Oil is captured in a removable container and held for proper disposal.
- 8 Separated water is drawn from the bottom of the settling chamber for final purification.

- 9 Separated water flows downward through a pre-adsorber that captures additional oil and protects the carbon bag(s) that follow.
- 10 Activated carbon removes oil to a residual level of 20 ppm or lower. Depending on the size of the unit, one or two carbon adsorption chambers will be present.
- 11a Purified water is drawn from the bottom of the carbon adsorption chamber and then either exits the unit (11b) or passes into the second carbon adsorption chamber if present.

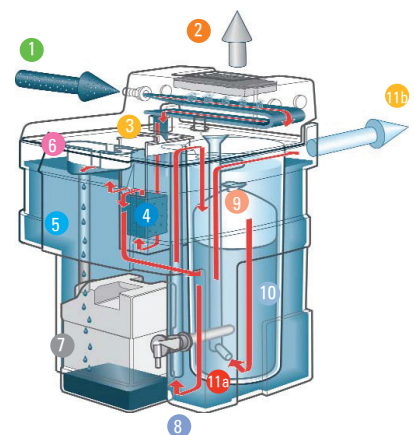

DS SERIES TECHNICAL SPECIFICATIONS



DS SERIES Model Comparison

Model	Compressor Capacity Nominal (scfm)	Vessel	Volume (gal)			Dimensions (inches)			Weight (lbs)
			Preadsorber	Activated Carbon	Oil Container	H	W	D	
DS0070	70	6.6	0.24	0.8	0.7	22	14	13	19
DS0145	145	13.2	0.85	2.1	1.3	26	18	17	43
DS0265	265	19.8	1	3.2	2.6	29	20	18	52
DS0530	530	39.6	1.3	2 x 2.9	5.3	33	27	20	77
DS1060	1060	79.2	1.5	2 x 4	5.3	39	31	26	148
DS2120	2120	159	2 x 1.5	4 x 4	2 x 5.3	39	70	26	300
DS4240	4240	317	4 x 1.5	8 x 4	4 x 5.3	39	148	26	600

Due to a continuous program of product improvement, specification and dimensions are subject to change without notice.

DS SERIES Model Selections

Maximum Compressor Capacity (cfm) for Moderate Climates*

Model Number	Screw & Rotary Vane Compressors with Oil Injection Cooling		Piston Compressors	
	Mineral Oil	Synthetic Oil	Mineral Oil	Synthetic Oil
DS0070	71	71	71	71
DS0145	147	147	147	106
DS0265	282	212	212	177
DS0530	565	424	424	353
DS1060	1131	848	848	707
DS2120	2262	1696	1696	1413
DS4240	4523	3392	3392	2827

*Moderate climate (68°F, 70% RH). For tropical climate (100°F, 90% RH), reduce capacity by 1/3.

Optional Accessories

Thermostat Controlled Heater

If the DS Oil/Water Separator is installed in an area where the ambient temperature might go below 34°F, use the optional thermostat controlled heating unit to prevent freezing of the condensate.

Condensate Distribution Manifolds

Often more than one separator will be required to meet the needs of a given operation. In those instances, distribution manifolds are available to assure that condensate is evenly distributed among the connected oil/water separators.

Notes

- Only for compressed air condensate.
- Donaldson guarantees a residual oil content of less than 20 ppm in accordance to EN ISO 9377-2 with DS Oil/Water Separators.
- The warranty only applies to:
 - Proper use with an oil/water mixture from air compressor condensate
 - Use of original replacement and spare parts.
 - Proper installation and commissioning according to the manual.