

Equalizer

An accessory designed to collect and manage high volumes of condensate for multiple oil/water separators.



Features

Automatically equalizes flow to multiple units

Multiple inlet/outlet connections

Large storage reservoir

Benefits

Helps improve operation of oil/water separators

Supports system expansion
Balances up to 4 oil/water separators

Ideal for large capacity level drains
Handles in-rush from various drains

Equalizer

How it Works

Condensate enters the Equalizer through inlet ports on the diffuser. The Equalizer automatically slows down the flow of the condensate as it distributes to multiple oil water separators. A diffuser pad serves to contain the condensate and reduce misting. The depressurized condensate drains into the collection and storage vessel where any solids drop out and the condensate accumulates. The condensate is then distributed to the oil/water separator(s).

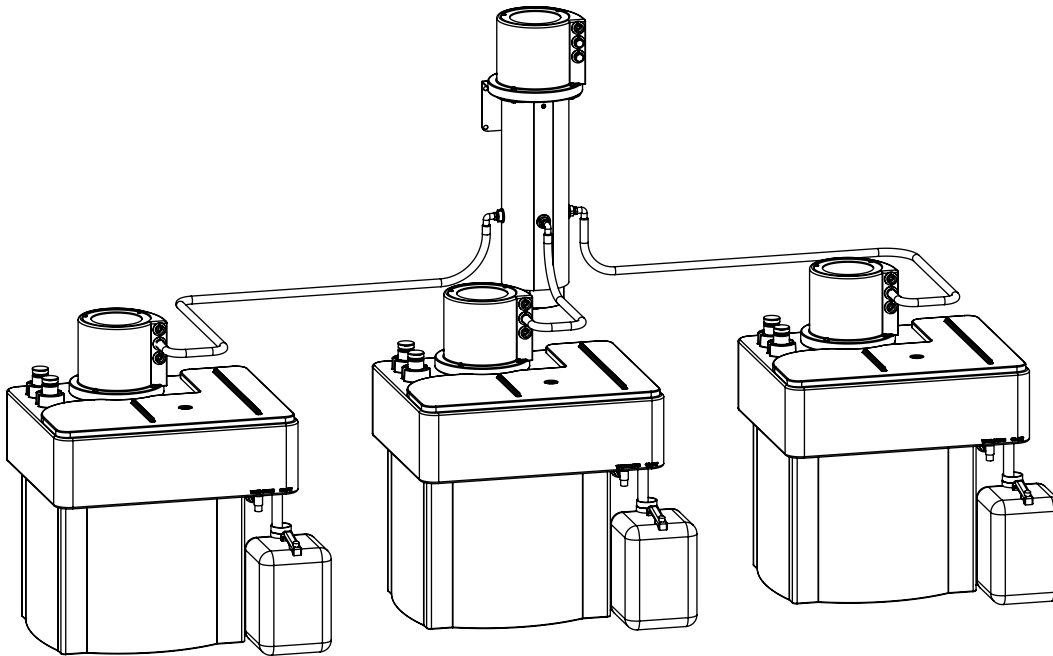

Dimensions

Model	Inlets	Outlets	Working Capacity (Gallons)
PSEQ1	Up to Three (3) ½" NPT	Three (3) ½" NPT	2.4
PSEQ2	Up to Three (3) ½" NPT	Four (4) ½" NPT	2.4



Air & Vacuum Process, Inc.
Toll Free 866-660-0208
www.airvacuumprocess.com
sales@airvacuumprocess.com

All design specifications are subject to change without notice.

© 2017 FGA-072-110317-01