



External Pneumatic Operated Condensate Drain

Robo-Drain RD11



A fully automatic, zero loss drain that requires no electricity.

Translucent reservoir for visual assurance of operation.

Ideal for Oil/Water Separators.

Features

Large 28 oz. capacity discharge

Isolated trigger assembly

Non clogging

Low profile

Translucent reservoir

Full port drain valve

Fully pneumatic

Automatic design

Made in the USA

Benefits

Ideal for most compressor installations

Reliable design – unaffected by contaminants

Saves valuable air. Saves money

Fits in tight spots

Easy-to-see condensate level
“Quick check”

Handles scale and rust without clogging

No electricity required

Operates on demand

Model No. RD11

Specifications

Inlets: (2) 3/4" NPT

Outlet: 1/2" NPT

Power: Clean, Dry Compressed Air
80 to 130 PSI

Pressure: 0 to 250 PSI

Operating Temperature: 32° to 180° F.

Weight: 17 lbs.

Discharge: 24 ounces per cycle

Materials

Reservoir: Aluminum and Composite

Valve: Bronze w/S.S. Ball and Stem

Float: Stainless Steel

Seat: Stainless Steel

Seal: Viton®*

Consult factory for additional Options

How It Works

Condensate enters the drain through one of two inlet connections. As condensate is collected and the translucent reservoir fills, a stainless steel float mechanism rises. When the condensate reaches a design level, the float mechanism actuates an isolated magnetic trigger assembly. The trigger assembly directs control air to the valve actuator, which in turn opens a full-port drain valve.

Condensate will then exit the unit. As the float drops, the trigger assembly closes the control air line and the valve actuator closes the ball valve. The drain is then returned to the collection mode.

Dimensions

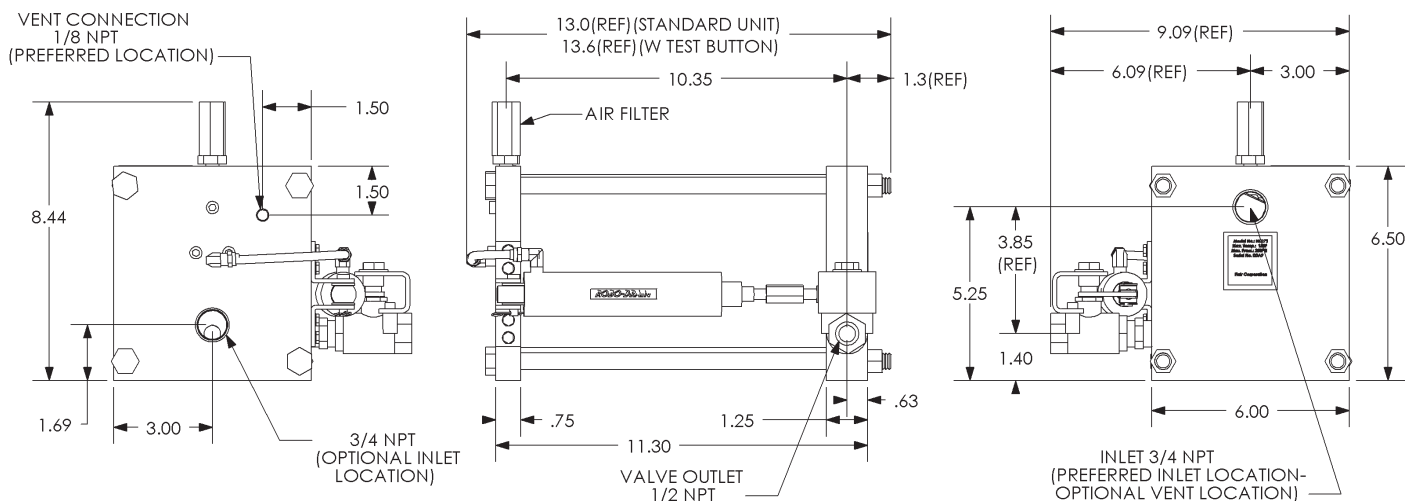

Distributed by:
Air & Vacuum Process, Inc.
Phone: 281-866-9700
Fax: 281-866-9717
sales@airvacuumprocess.com



AIR SYSTEM PRODUCTS
51 Beach Ave.
Lancaster, NY 14086

All design specifications are subject to change without notice.

* Viton is a registered trademark of Dupont Dow Elastomers.

© 2016 Bulletin FGA-024-091916-01