

# Coalescing Filters - to 285 psig

285psig @ -20 to 100°F  
260psig @ -20 to 200°F

Series R30- Enameled Carbon Steel ♦ Series R32- 304 Stainless



- Intake Air/Gas/Mist Flows to 100,000 SCFM Std.
- ASME U Stamp Std., Nat'l. Board Registered
- Pleated Element Design - Exceptional Filter Area, Low ΔP, High Flow
- Hinged Flange and Lift Lug Std., Service Access W/O Breaking Connections
- 304SS Throat Safety Cages and ΔP Taps Std.
- Rugged Enameled Steel or 304SS Construction

Series R30 coalescing pipeline filters are fabricated from rugged enameled carbon steel, (R32 are 304SS), designed, constructed, and stamped in accordance with ASME Boiler and Pressure Vessel Code requirements for unfired pressure vessels. Any model can be modified to more exactly fit your needs.

- **Standard Connection Sizes from 1" to 12"** Male NPT or raised face flange in-line connections are std. Alternative orientations and sizes are available. An elevated discharge connection is shown below. A hinged blind face flange closure assembly with lift lug is standard.
- **Coalescing Filter Media.** Sparks™ #907 media is composed of microfine borosilicate glass fibers bonded with phenolic resin. Together with a textile prefilter and a final drain layer, these pleated elements are remarkably effective at coalescing fine entrained oil and aqueous vapor mist from air/gas flows with very low ΔP. Experience has demonstrated high removal (over 90%) in dealing with 1.0 to 0.3μ aerosols. **Other optional filter media such as #926 exceeds 95% removals.** Individual performance will vary with the specific viscosity and vapor pressure of liquid contaminants.

- **Options:** Models R30-0202-MT-020 and larger include CS leg supports. (add 18" to OH) Carbon steel support legs in any length, gauges, special finishes, and head lift assemblies are optional on any model. Call for information on vessels having other pressure services, 304SS, or other materials of construction.

[See pgs. 13 & 14 for more options and a worksheet to fax back to us.](#)



Coalescing filter in service cleaning an eight inch gas pipeline in the midwestern US.

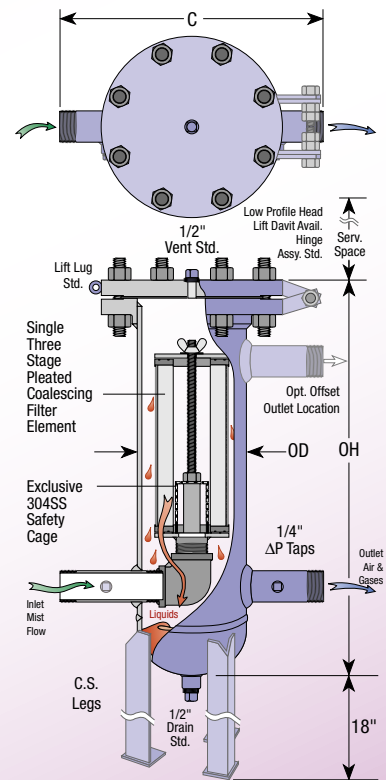

Housing Model No.	Conn. Size	Conn. Type	Cover Style	Dimension in Inches				Wgt. Lbs.	Order Element No.
				OD	OH	C	Serv. Space		
R30-0200-MT-010	1"	MPT	Blind Flg.	6 5/8"	24	16	16	130	321-1439WK907
R30-0201-MT-015	1 1/2"	MPT	Blind Flg.	6 5/8"	28	16	16	140	321-3235WK907
R30-0202-MT-020	2"	MPT	Blind Flg.	8 5/8"	28	16	16	150	321-3236WK907
R30-0203-RF-030	3"	Flg.	Blind Flg.	8 5/8"	39	20	24	200	321-3237WK907
R30-0204-RF-040	4"	Flg.	Blind Flg.	10 3/4"	42	20	24	325	321-3238WK907
R30-0205-RF-060	6"	Flg.	Blind Flg.	12 3/4"	51	24	26	500	321-3239WK907
R30-0206-RF-080	8"	Flg.	Blind Flg.	16	66	28	36	850	321-3240WK907
R30-0207-RF-100	10"	Flg.	Blind Flg.	20	76	32	36	1200	321-3241WK907
R30-0208-RF-120	12"	Flg.	Blind Flg.	24	78	36	39	1400	321-3242WK907

